

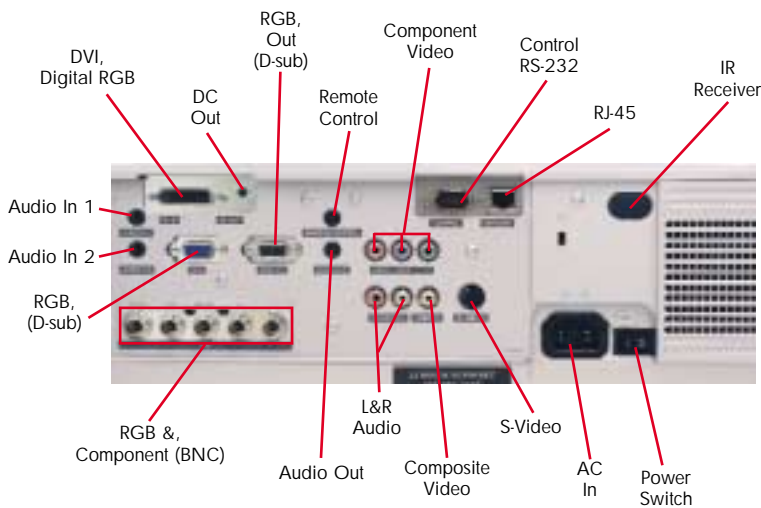

ImagePro 8935 Portable LCD Projector

- 3500 lumen brightness
- XGA resolution
- 800 to 1 contrast ratio
- Easy lamp replacement
- Optional bayonet lenses available
- Lens shift
- Progressive scan
- Keystone correction
- Network capability



Exclusive five year warranty
the best warranty in the industry



8935 DUKANE

ImagePro 8935

Portable LCD projector

The Dukane ImagePro 8935™ delivers high brightness, that can be used in a wide range of places. The lens shift function and a selection of optional, interchangeable lenses also contribute to installation ease. A wide variety of functions for high picture quality and network capability will meet your most demanding needs. Providing realistic colors, sharp contrast, and super bright images. The 8935 enables presentations with persuasive impact in a variety of situations.

Position the 8935 on a table, rack, or installed in a ceiling mount. The unit can be controlled by the remote control and easily adjusted even when ceiling mounted.



This full-featured LCD projector is ideal for classrooms, conference rooms or other locations where a bright image is required.

Key features:

- 3500 lumen brightness
- XGA resolution
- 800 to 1 contrast ratio
- Easy lamp replacement
- Optional bayonet lenses available
- Lens shift
- 2000 hour lamp life
- Progressive scan technology
- Remote control
- Digital keystone correction
- Network capability
- Picture-In-Picture
- Five year warranty and One year Peace-of-Mind service

DUKANE

Dukane Corporation
 Audio Visual Products Division
 2900 Dukane Drive
 St. Charles, Illinois 60174
 800-676-2485 or 2486
 630-584-5156
 avsales@dukcorp.com
 www.dukcorp/av.com



toll-free
 fax
 e-mail

ImagePro is a registered trademark of Dukane Corporation
 #11638-C-05

Specifications 8935

Image Element	0.99" polysilicon TFT x3, MLA
Brightness	3500 ANSI lumens 2800 (whisper mode)
Resolution	1024 x 768 pixels (H X V), XGA
Contrast	800 to 1
Scanning Frequency	fh 15-91 kHz, fv 50-120 Hz
Lens	Power zoom (F=1.7 to 2.4), 1.5X
Lens Throw Ratio	1.5 -2.2:1 throw distance to image width
Keystone Correction	Digital, vertical +/-15 deg, horizontal +/- 5 deg
Aspect Ratio	4:3, 16:9, selectable
Computer Compatibility	SVGA, VGA, XGA, and SXGA/UXGA Compressed, Mac 13" and Mac 16"
Video Compatibility	NTSC, NTSC 4.43, PAL, PAL-M, PAL-N, PAL60, SECAM, HDTV 1080i, 720p, 575i, 480i/p
Image Control	Freeze function, electronic magnification and pan
Mouse Control	Using M1 to USB
Projection Modes	Front/rear/ceiling
Color Reproduction	24 bit (16.7 million)
Lamp	275W UHB
Lamp Life	2000 hours
Audio	1.0 W x 2
Throw Distance	46" to 364"
Screen Size, diagonal	40" to 500"
Inputs, Video	(1) Component, RCA x 3, BNC (shared) (1) S-video, Min DIN 4-pin, (1) Composite video, RCA x 1 Audio, Stereo, RCA x 2,
Inputs, Computer	(1) RGB Signal: D-sub, 15 pin (1) BNC x 5 (shared), RGBHV (1) M1-D (digital RGB) & Audio, Stereo mini jack x 2
Outputs Monitor	15 pin, D-sub Audio, Stereo mini jack x 1
Outputs, Control	9 pin D-sub Connector, RS-232 M1-D with USB for mouse 3.5mm mini jack (wired remote control)
Network	RJ-45 port / 10Base-T
Security	Kensington slot
Fan Level	39dB, (35dB in whisper mode)
Operating Temperature	32 to 95 deg. F (0-35 deg C)
Power	AC 100-120V, AC220-240V 50/60 Hz, 430 watt
Size (WxHxD)	16.5" x 6.3" x 12.6"
Weight	17 lbs.
Carton Size	20.5" x 13.5" x 19
Shipping Weight	27 lbs.
Accessories Included	Remote control, batteries, power cord, RGB Cable, Video/Audio Cable, M1 cable (DVI & USB to M1), and operator/safety manual.
Safety	UL/CSA, FCC/DOC Class B, CE
Optional Accessories	Lamp 456-8935

Five (5) year limited warranty on parts and labor in North America,
 lamp excluded (for other locations, local warranties apply). Includes
 Dukane's FREE 1 year *Peace-of-Mind Loaner Program*.

5YR