

BrightLink[®] Interactive Series

Projectors
Interactive

575Wi

Widescreen

585Wi

Widescreen

Ultra-bright



BrightLink 585Wi shown
Wall mount included.

The bright choice in interactive projectors for today's BYOD classroom.

3x Brighter Colors¹, and reliable performance — 3LCD, 3-chip technology

One measurement of brightness is not enough — look for both high color brightness and high white brightness. The BrightLink 575Wi and 585Wi have:

Color/Interactive Brightness — 2700 lumens² (575Wi) and 3300 lumens² (585Wi)

White/Interactive Brightness — 2700 lumens² (575Wi) and 3300 lumens² (585Wi)

PC-free interactivity — display and write on content from your iPad[®]/iPod[®]/iPhone[®], Android[™] device³, document camera, DVD player, or no source at all

Convenient collaboration for BYOD classrooms — wirelessly share⁴ and compare students' work from multiple devices, simultaneously, with Moderator software⁵

Wireless interactivity — use EasyMP[®] software with a networked BrightLink projector to share and interact with content from your laptop as you move freely about the classroom

Dual pen support — allows two users to annotate simultaneously anywhere on the surface on which the image is projected

Compatible with top interactive software — maximize your investment by utilizing familiar teaching applications such as Promethean[®] ActivInspire[®] and SMART Notebook[™] (sold separately)

Wall mount included — get a 100" image from as little as 12" away; significantly reduces shadow interference and glare





The bright choice in interactive projectors for today's BYOD classroom.

The BrightLink 575Wi and 585Wi bring cutting-edge kinesthetic learning to the BYOD classroom. Offering 3x Brighter Colors¹ than competitive models, Epson 3LCD projectors ensure bright, vivid lessons. The 575Wi and 585Wi ultra-short-throw projectors deliver dynamic images, whatever the task at hand. And, they display images up to 100" from just 12" away. Best of all, with PC-free interactivity, these projectors make it easy to walk in and start an interactive session on any wall or whiteboard. Instructors can use the Moderator software to share students' work over the network from multiple devices, simultaneously. Or, they can wirelessly project content from iOS® or Android devices or utilize popular learning applications.

Projectors at a glance



	BrightLink 575Wi	BrightLink 585Wi
Resolution:	WXGA (1280 x 800)	WXGA (1280 x 800)
Color Brightness:	2700 lumens²	3300 lumens²
White Brightness:	2700 lumens²	3300 lumens²
Interactive Brightness:	2700 lumens²	3300 lumens²

Advanced connectivity



Wireless interactivity

When using Epson EasyMP software with a networked BrightLink projector, teachers are no longer tied down by restrictive and confining cables. Educators can wirelessly display and interact with content as they move about the classroom with their laptop, experiencing a whole new level of interactive freedom.



Advanced network connectivity and management capabilities

Present A/V content over the LAN or annotate on network content using BrightLink's instant annotation tools. With Epson's EasyMP Monitor software, IT administrators can configure and monitor the status of their Epson networked projectors, including the remote viewing of power status, lamp hours and temperature/filter conditions.

Epson iProjection™ App⁴

Display, annotate and control content from your iOS or Android mobile device with the free Epson iProjection App. Teachers can walk around the class and still share engaging content. The app is easy to use and navigate with intuitive menu options that make it simple to bring iOS and Android content to the big screen.

Amazing image quality



BrightLink 575Wi



BrightLink 585Wi

3x Brighter Colors with Epson¹

Brilliant image quality requires high color brightness (color light output), and Epson 3LCD projectors have 3x Brighter Colors than leading competitive projectors.¹

One brightness measurement (lumens) is not enough. A projector's specification needs to show both high color brightness and high white brightness. If color brightness is lower than white brightness, images may be dark, dull and lose detail. If not provided, be sure to ask for a projector's color brightness specification.

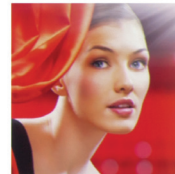

EPSON

High color brightness and high white brightness

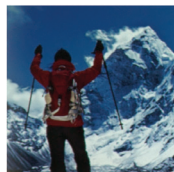

COMPETITOR

Color brightness significantly lower than white brightness

Actual photographs of projected images from an identical signal source. Price, resolution and white brightness are similar for both projectors (Epson 3LCD and 1-chip DLP competitor). Both projectors are set to their brightest mode.

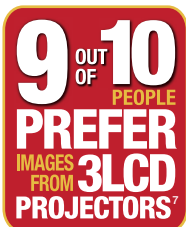

3LCD — The #1 projection technology in the world

- All 3LCD projectors have both high color brightness and high white brightness
- All 3LCD projectors have 3 chips
- 25% lower power consumption for lower energy costs⁶
- 20 years of road-tested reliability



Classroom collaboration

Teaching tools

Support BYOD classroom collaboration using Epson's Moderator feature⁵.

- Moderator (teacher) can display up to four different device screens simultaneously and control which device screens to display
- Connect to up to 50 Windows®, Mac®, iOS or Android devices
- Encourage and control classroom collaboration; perfect for comparing students' work side-by-side

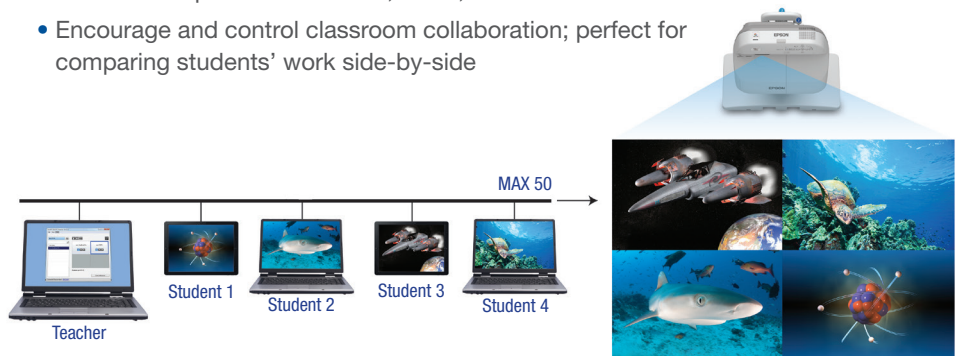

Easy Interactive Tools 3.0

This new annotation software from Epson allows users to control projector settings over the network; record and save video from Epson document cameras; save, re-open and edit annotation files; access archived curriculum; and program the interactive pen button to provide instant access to the most-used tools. Best of all, Easy Interactive Tools is free and ships with each BrightLink projector.



SMART Notebook software for BrightLink

This collaborative learning software (full version) helps teachers create high-impact lessons — anytime, anywhere. It offers a multitude of digital resources as well as customizable content. Each BrightLink purchased with this optional software includes a four-seat user license, available for Windows and Macintosh®.



Promethean ActivInspire

ActivInspire software enables teachers to engage their students in interactive activities that are sure to grab their attention. Each BrightLink purchased with this optional state-of-the-art software includes a full version, five-seat user license, available for Windows and Macintosh operating systems.

Save energy and reduce operating costs

- **ECO Mode** — operates the projector at a lower brightness setting
- **Light Optimizer Mode** — adjusts the lamp brightness, based on the projected image
- **Auto Mode** — sensor automatically adjusts the lamp brightness, based on the room environment
- **Lamp dimming** — after a certain period of inactivity, the projector lamp dims, thereby extending the lamp life
- **Sleep Mode (A/V Mute)** — control your presentation; it's right at your fingertips
- **Direct Power On/Off** — power the projector on/off with the flip of a wall switch
- **Standby audio** — even when the projector is in Standby Mode, you can use the projector's internal speaker or pass audio out to an external speaker

Easy to use



Simple Setup Suite from Epson

Epson projectors offer a suite of innovative features that ensure flexible placement and fast, easy setup.

- **Auto calibration** — get up and running in no time
- **2x HDMI** — use with multiple high-definition A/V devices. (Compatible with the latest laptops, Blu-ray Disc® and media players)
- **MHL** — the latest in connectivity⁸
 - Display content with MHL-enabled smartphones, tablets and Roku® devices⁹
 - Use the projector remote to control MHL-enabled devices
 - Charge your MHL-enabled device when it's plugged into the projector
 - Get instant access to movies, games and more
- **Quick Corner®** — this innovative feature allows you to move any of the four corners of an image independently, to adjust each corner for a perfectly rectangular picture
- **Quick, convenient control** — Instant Off® means no cool-down time required; it's ready to shut down when you are
- **Copy menu settings for multiple projector installations** — save on installation time; copy settings via a USB flash drive, USB cable or LAN
- **Flexible wall mount (included)** — the telescopic arm makes it easy to mount the projector, and then adjust the image, on any surface including plain walls and existing boards, as well as thicker boards

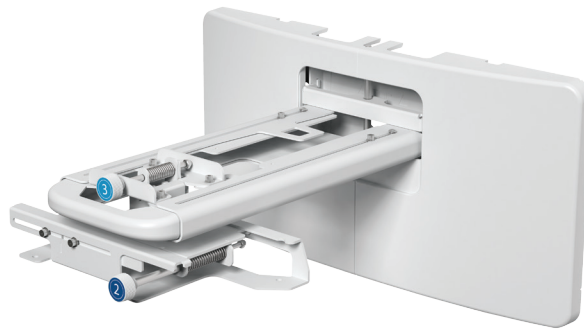

Better Products for a Better Future™
eco.epson.com



- 1 Compared to leading 1-chip DLP business and education projectors based on NPD data, July 2011 through June 2012. Color brightness (color light output) measured in accordance with IDMS 15.4. Color brightness will vary depending on usage conditions.
- 2 Color brightness (color light output) and white brightness (white light output) will vary depending on usage conditions. Color light output measured in accordance with IDMS 15.4; white light output measured in accordance with ISO 21118.
- 3 Functionality may vary depending on hardware, application, and/or provider restrictions or limitations. Devices and cables not included.
- 4 Check your owner's manual to determine if a wireless LAN module must be purchased separately to enable wireless connection on your Epson projector. Epson projectors can be networked either through the Ethernet port on the projector (check model specifications for availability) or via a wireless connection. Not all Epson projectors are able to be networked. Availability varies depending on model.
- 5 Moderator feature is part of EasyMP Multi-PC Projection software.
- 6 Data source: ProjectorCentral.com, Jan. 2014. Average of 1,243 shipping models for which the manufacturers provided lumens and total power data, all resolutions and brightness levels. Energy efficiency was measured as wattage per lumen. It was measured for both 3LCD and 1-chip projectors in each of six brightness segments. 3LCD projectors averaged less required electricity per lumen in each of the six segments.
- 7 9 out of 10 people preferred images from leading 3LCD projectors over leading 1-chip DLP business and education projectors. Leading projectors selected according to NPD data as of July 2013. Based on independent U.S. research conducted by Radius Research (July 2013).
- 8 Includes one Mobile High-Definition Link® (MHL) HDMI port.
- 9 Roku Streaming Stick™ allows you to watch content from popular Internet streaming services. Roku Streaming Stick only available in the U.S.
- 10 ECO Mode is up to 10,000/6000 hours (575Wi/585Wi). Normal Mode is up to 5000/4000 hours (575Wi/585Wi). Lamp life will vary depending upon mode selected, environmental conditions and usage. Lamp brightness decreases over time.
- 11 See our website for convenient and reasonable recycling options at www.epson.com/recycle
- 12 SmartWay is an innovative partnership of the U.S. Environmental Protection Agency that reduces greenhouse gases and other air pollutants and improves fuel efficiency.

Specifications and terms are subject to change without notice. EPSON, EasyMP, Instant Off, Quick Corner and PowerLite are registered trademarks, EPSON Exceed Your Vision is a registered logomark and Better Products for a Better Future and Epson iProjection are trademarks of Seiko Epson Corporation. BrightLink and PrivateLine are registered trademarks, Built to Perform and Pilot are trademarks and Epson Connection is a service mark of Epson America, Inc. iPad, iPhone, iPod, Mac, Mac OS and Macintosh are trademarks of Apple Inc., registered in the U.S. and other countries. Android is a trademark of Google Inc. SmartWay is a service mark of the U.S. Environmental Protection Agency. All other product and brand names are trademarks and/or registered trademarks of their respective companies. Epson disclaims any and all rights in these marks. Copyright 2014 Epson America, Inc. Com-SS-Oct-13 CPD-40836 02/14

Specifications

Projection System Epson 3LCD, 3-chip technology
Projection Method Front/rear/wall mount/table
Driving Method Epson Poly-silicon TFT Active Matrix
Pixel Number 1,024,000 dots (1280 x 800) x 3
Color Brightness²
 (Color Light Output) 575Wi: 2700 lumens, 585Wi: 3300 lumens
White Brightness²
 (White Light Output) 575Wi: 2700 lumens, 585Wi: 3300 lumens
Interactive Color Brightness²
 (Color Light Output) 575Wi: 2700 lumens, 585Wi: 3300 lumens
Interactive White Brightness²
 (White Light Output) 575Wi: 2700 lumens 585Wi: 3300 lumens
Aspect Ratio 16:10
Native Resolution 1280 x 800 (WXGA)
Lamp Type 575Wi: 215 W UHE, 585Wi: 245 W UHE
575Wi Lamp Life¹⁰ Up to 10,000 hours (ECO Mode)
 Up to 5,000 hours (Normal Mode)
585Wi Lamp Life¹⁰ Up to 6000 hours (ECO Mode)
 Up to 4000 hours (Normal Mode)

Size (projected)
 Area: 4:3 53" – 88"
 16:10 60" – 100"
 16:9 59" – 97"

Keystone Correction (manual)
 Horizontal: ± 3 degrees; Vertical: ± 3 degrees

USB Plug 'n Play
 Mac OS® 10.5/10.6/10.7/10.8/10.9

USB Plug 'n Play for Windows
 2000 XP/Windows Vista®/Windows 7/Windows 8

Contrast Ratio Up to 10,000:1
Color Reproduction Up to 1 billion colors

Projection Lens

Type Manual focus
F-number 1.80
Focal Length 3.71 mm
Throw Ratio Range
 (16:10) 0.27 – 0.37, (4:3) 0.33 – 0.44, (16:9) 0.27 – 0.37
Zoom Ratio Digital zoom 1.0 – 1.35x

Other

Display Performance NTSC: 480 lines, PAL: 576 lines
 (Depends on observation of the multi-burst pattern) Color Modes
Input Signal NTSC/NTSC4.43/PAL/M-PAL/N-PAL/PAL60/SECAM
Speaker 16 W monaural
Operating Temperature 41 ° to 95 °F (5 ° to 35 °C)
Power Supply Voltage 100 – 240 V ±10%, 50/60 Hz
Power Consumption 575Wi: 333 W, 585Wi: 376 W
 4.3 W standby (Communication On)
 0.33 W standby (Communication Off)
Fan Noise 35 dB (Normal Mode), 28 dB (ECO Mode)
Security Kensington® lock provision, security anchor bar,
 password protection function

Interactivity

Interactive Technology Infrared, 940nm
Interactive Area (image size)
 575Wi/585Wi: 60-100" diagonal (16:10, WXGA)
Interactive Modes Computer Interactivity/input:
 Interactive and Whiteboard modes Annotation, dual user
PC-Free Annotation, dual user
Annotation Tools Epson Easy Interactive Tools, dual user
PC Annotation Sources USB, HDMI, Computer 1,
 Computer 2, LAN
PC-Free Annotation Devices Document Cameras, DVD/
 Blu-Ray Disc player, iPod/iPad devices³
Calibration Method Automatic or Manual
Interactive Connectivity USB cable for non-networked & LAN
Interactive Software Requirements
 Epson Easy Interactive Driver (Mac only)
 Windows and Linux: no driver required
 Macintosh: Mac OS X 10.5/10.6/10.7/10.8/10.9
 Epson Easy Interactive Tools for Windows and Macintosh

Interfaces

Wireless LAN port: 802.11 b/g/n
 (optional – module sold separately)

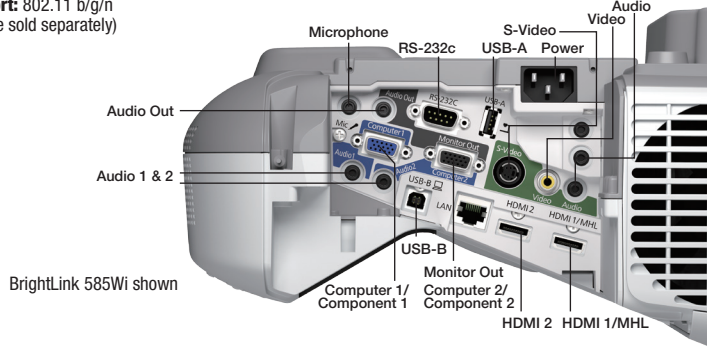

Interactivity (continued)

System Compatibility:
 Microsoft Windows XP SP2, Windows XP SP3
 (Home Edition/Professional), Windows Vista, Windows Vista SP1,
 Windows Vista SP2 (All editions except for Starter), Windows 8.x,
 Windows 7 SP1 (All editions except for Starter)
 Mac OS X 10.5/10.6/10.7/10.8/10.9

Optional Software
 SMART Notebook
 Windows: Pentium® 4 processor or better, 2 GB of RAM, 2.5 GB of
 free hard disk space for SMART® education software installation
 (an additional 600 MB is required for complete Gallery
 installation) Windows XP SP3, Windows 7 SP1 or Windows 8
 operating system
 Macintosh: Intel® Core™ 2 Duo processor or better, 2 GB of RAM,
 2 GB of free hard disk space for SMART education software
 installation (an additional 600 MB is required for complete
 Gallery installation) Mac OS X 10.7 or 10.8 operating
 system software

Promethean ActivInspire
 Windows: Recommended Specs: 2.0 GHz Intel Core 2 Duo or
 faster for HD-quality videos, 1GB of RAM is required to play
 HD-quality videos, 1024 x 768 resolution, 1.5 GB of free disk
 space; Minimum Specs: Pentium 4 – 1GHz (800MHz for Vista),
 512MB of RAM, 1024 x 768 resolution, 1.5GB of free disk space;
 Macintosh: Recommended Specs: 2.0GHz Intel Core 2 Duo,
 512MB of RAM, 1024 x 768 resolution, 3.0GB of free disk space;
 Minimum Specs: Intel Processors (Universal Binary), 512MB of
 RAM, 1024 x 768 resolution, 3.0GB of free disk space

Interactive Input Device

Type of Interactive Input Device Digital Pen
Interactive Pen Functions Mouse functions (left and right
 click), Electronic pen, LED battery status indicator
Interactive Pen Power AA battery, rechargeable
Compatible Pen Battery Types
 SANYO Eneloop® HR-3UTG/HR-UTGA (Eneloop batteries included.
 Eneloop is registered trademark of Sanyo Electronic Co. Ltd.,
 Manganese dry cell, alkaline dry cell)

Interactive Pen Dimensions 6.4" x 0.94"

Interactive Pen Weight 1.1 oz (without battery)

Dimensions (W x D x H)

Excluding feet: 14.5" x 14.8" x 6.1"
 Weight: 12.1 lbs.

Remote Control

Features Computer, video, USB, LAN, source search, power,
 aspect, color mode, volume, e-zoom, A/V mute, freeze, menu,
 help, auto, enter, esc, pointer, user Operating Angle
Rear: Right/left: -55 to +55 degrees,
 Upper/lower: +75 to +15 degrees
Front: Right/left: -30 to +30 degrees,
 Upper/lower: 0 to +60 degrees
Operating Distance 19.7 ft (6 m)

Support

The Epson ConnectionSM
 Pre-sales support U.S. and Canada 800-463-7766
 www.epson.com
 www.epson.com/brightlink

Support (continued)

Service Programs
 Two-year projector limited warranty, Epson Road Service
 program, PrivateLine® dedicated toll-free support and 90-day
 limited lamp warranty

What's In the Box

A BrightLink 575Wi or 585Wi ultra-short-throw interactive
 projector, projector wall mount, projector template sheet,
 installation guide, quick user's guide, power cable, USB A/B
 cable, computer/VGA cable, electronic user manual,
 interactive driver for Mac, Epson Easy Interactive Tools,
 Network Management software, projector remote control,
 two (2) interactive pens, pen tray, two (2) AA batteries (for
 interactive pens) + battery charger, two (2) AA batteries
 (for remote)

Eco features

Energy-efficient 3LCD light engine
 RoHS compliant
 Recyclable product¹¹
 Epson America, Inc. is a SmartWaySM Transport Partner¹²

Ordering Information

Product Name	
BrightLink 575Wi	V11H601022
BrightLink 585Wi	V11H600022

Accessories

Genuine Epson lamp 575Wi:	V13H010L79
585Wi:	V13H010L80
Replacement air filter	V13H134A40
Promethean ActivInspire software	V12HPSW001
SMART Notebook software	V12HSSW020
Component video cable	
HD15/3RCA (male), 3.0 m	ELPKC19
Wall mount	V12H675020
Table projection mount	V12H516020
Wireless microphone	V12H4430M2
External speakers (ELPSP02)	V12H467020
Wireless 802.11b/g/n LAN unit	V12H418P12
Quick wireless USB key	V12H005M09
DC-06 USB document camera	V12H321005
DC-11 document camera	V12H377020
DC-12 document camera	V12H594020
DC-20 document camera	V12H500020
Easy interactive pen A (orange)	V12H666010
Easy interactive pen B (blue)	V12H667010
Replacement pen tips	V12H668010
Interactive Pen Extension	V12H590002
USB extension cable	V12H525001
PowerLite® Pilot™ connection and control box	V12H614020
16:10 height adjustable cart for Epson	V12H457008
90" whiteboard	V12H468002
96" whiteboard	V12H468001