

INPUT AND OUTPUT TERMINALS:

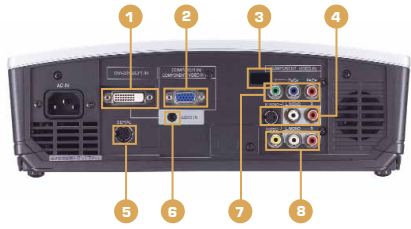

1. DVHD (HDCP) INPUT
2. RGB IN
3. REMOTE IR
4. S-VIDEO INPUT
5. RS-232C
6. PC AUDIO INPUT
7. COMPONENT VIDEO IN
8. COMPOSITE VIDEO INPUT

DIMENSIONS: unit: mm, inch

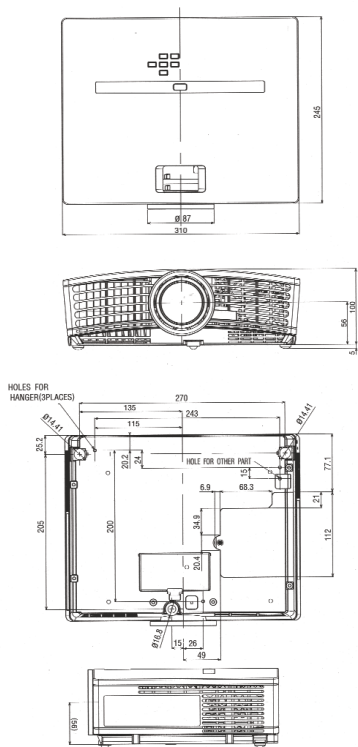

HC100 SPECIFICATIONS:

DISPLAY TECHNOLOGY	0.55" Wide, 1-Chip DMD, 12 deg. DDR, DDP2000
RESOLUTION	854 x 480 (Total 409,920 pixels), 600 Video Lines
BRIGHTNESS	1300 ANSI lumens Min:910 lm
COLOR	16,770,000 colors
CONTRAST RATIO	2000 : 1 (on/off)
ZOOM/FOCUS	Manual Focus & Zoom Lens
PROJECTION LENS	F= 2.4 - 2.7, 100°@3.6m (Wide)
OFF SET AXIS	2 : -1 up (No variable lens shift)
PICTURE SIZE	40-275 (inch)
SOURCE LAMP	200W (Shut Off Time 2000 Hrs) with Low Mode (160 W : Shut Off Time 3000 Hrs)
PC COMPATIBILITY	Resolution: 640 x 480 - 1024 x 768 + Compressed 1152 x 870 Sync on Green available
VIDEO COMPATIBILITY	NTSC/NTSC 4.43/PAL (including PAL-M, N) /SECAM, PAL-60, DVD (Component) /HDTV (525p, 625p, 1080i (50, 60Hz), 720p (50, 60Hz)) /SCART (RGB + 1Vcomp)
INPUT TERMINALS	<p>RGB: Mini D-sub 15pin x 1 DVI-D (with HDCP) x 1</p> <p>Audio: Stereo Mini Jack (ø 3.5mm) x 1 RCA x 1 + S-VIDEO x 1 RCA (Y, CB, CR) x 1</p> <p>Audio: RCA (L, R) x 2</p>
COMMUNICATION TERMINAL	RS-232C; 8pin x 1
SCANNING RATE	[H] 15 - 80 kHz [V] 50 - 85 Hz [Dot Clock] max 100 MHz
AUDIO SPEAKER	2 W Mono
HEIGHT ADJUSTER	One Push Rear Leg (-1 to 7 degree variable)
OUTSTANDING FEATURE	<ul style="list-style-type: none"> • sRGB specification mode • Digital keystone-correction for Vertical (without auto) • Video Line Doubler (DDP2000) ; 3:2 pull-down • 3D-Y/C • 10 Languages OSD • Password Lock
HAND REMOTE UNIT (SYSTEM OPERATION REMOTE*)	(1) Projector Fully Control (2) DVD, VCR control (learning type) (3) Back light key
POWER CONSUMPTION	280 W /2.9 A T.B.D
DIMENSION (W*H*D)	12.2" x 3.9" x 9.6" (exclude height adjuster)
WEIGHT	6.5 lbs
POWER REQUIREMENTS	AC 100 - 120V/ 220 - 240V /±10%, 50/60 Hz
FAN NOISE	33 dBA, sea-level
PACKAGE DIMENSION (W*H*D)	16.5" x 10.3" x 14.1"
PACKAGE WEIGHT	13.7 lbs
WARRANTY	Two-year parts and labor warranty and 90-day warranty on lamp (both warranties available in U.S. and Canada)
SUPPLIED ACCESSORIES	AC Power Cable: 2.9m (USA type x 1 / EUR continental type x 1) AV cable 2.9m (3 wires) RGB cable: 1.8m S-VIDEO cable: 2.9m RS-232C cable: 1.8m Remote Unit (incl. Battery) Quick Start Card User Manual (HC100: Eng/Fre/Spa/Chi/Kor), (HC100E: Eng/Fre/Spa/Ger/Rus/Ita/Por/Swe/NL)
OPTIONAL ACCESSORIES	Spare Lamp bulb (VLT-HC100LP) Ceiling mount bracket (PROJ-UCM)

PROJECTION DISTANCE AT EACH SCREEN SIZE:

SCREEN		DISTANCE FROM SCREEN				HEIGHT PROJECTED IMAGE (H)					
Diagonal Size	Width	Height		Max.Zoom	Min.Zoom	inch (H)					
inch	cm	inch	cm	inch	m	inch	m				
40	102	32	81	24	61	5.1	1.3	62	1.6	-2.8	-7.2
60	152	48	122	36	91	7.7	2.0	94	2.4	-4.3	-10.9
80	203	64	163	48	122	10.3	2.6	125	3.2	-5.7	-14.5
100	254	80	203	60	152	13.0	3.3	157	4.0	-7.1	-18.1
150	381	120	305	90	229	19.6	5.0	237	6.0	-10.7	-27.1
200	508	160	406	120	305	26.2	6.6	316	8.0	-14.2	-36.2
250	635	200	508	150	381	32.7	8.3	-	-	-17.8	-45.2
300	762	240	610	180	457	39.3	10.0	-	-	-21.4	-54.3

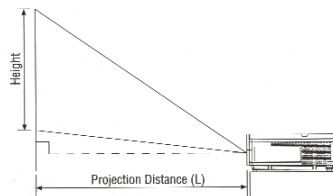

888.307.0349
www.mitsubishihomecinema.com

© 2004 Mitsubishi Digital Electronics America, Inc.
PP200410-11/04-10M-LITHC100

HC100

ULTRAPORTABLE COLORVIEW™
HOME THEATER DLP™ PROJECTOR

- 2000:1 Contrast Ratio ■
- HDTV Input Compatible ■
- 1300 ANSI Lumens ■

FOCUSED ON ENTERTAINMENT



LIGHT, BRIGHT, AND PRICED JUST RIGHT FOR THE IMAGE AND PRICE CONSCIOUS

For the smart and savvy consumer, Mitsubishi offers performance and versatility at an affordable price. With 1300 ANSI Lumens and a highly dynamic contrast ratio of 2000:1, the picture is clear and sharp even in a well-lit room. CineRichColor™ gives you the control to create the best possible color, focus, and contrast for various ambient light conditions or viewing applications. Other key features are an almost silent operation, an extended lamp life of over 3000 hours, and security functions. With high-quality CineView™ video-processing, the resulting picture quality from an "interlaced" source is absolutely superb and clearly artifact free. Rounding out a home cinema system with the HC100 projector will deliver a mind-blowing home cinema experience.

WHAT THE HC100 CAN DO FOR YOU:

- Turn watching a movie into a dynamic experience for friends and family.
- Turn watching a televised event into a social occasion.
- Full-immersion multi-user gaming.
- Home videos or digital slides shows let you re-live the event in larger-than-life scale.

ADVANTAGES OF HOME THEATER FRONT PROJECTORS:

- Projection screens only sit a few inches off the wall. It can truly be the television picture you hang on the wall, and using a retractable screen, the screen can disappear when not in use!
- By positioning the projector different distances to the viewing wall, you can realize screen sizes from 70 inches to 250 inches!
- The big screen doesn't require a big box. You can move the projector and screen to a different part of the house, or to a different house!



To find out more details about sRGB, visit us at:
www.mitsubishihomecinema.com

BRIGHTNESS AND CONTRAST: 1300 ANSI Lumens and 2000:1 contrast ratio—the brightness and contrast to be able to use in a living room or family room with limited light control.



CineRichColor™: This feature enables the user to adjust the picture to 10 different levels of white enhancement, or to select AUTO for factory adjusted settings based on input signals. As white is enhanced color range is compromised, so increased white enhancement can be used for PC, gaming or sports viewing use, and lower setting can be used for movies and TV material.

COMPACT SIZE: Lightweight with built-in sound for portable use.

RICH CONNECTIVITY: DVI-D (HDCP, or high-bandwidth, digital copy protection) plus VGA, Component Video, S-Video and Composite Video Inputs.



IMPRESSIVE PICTURE QUALITY

sRGB: Developed to ensure standard, uniform color reproduction regardless of the type of display used, sRGB color profile technology uses independent color coordinates common to all display technologies. As a result, it helps to eliminate hue variations that occur between different display systems and more accurately matches the way colors look in real life.



DLP™ TRUE VISION™ IMAGE PROCESSING:

- **Motion Adaptive De-Interlacing:** Offers optimal image de-interlacing for incredibly smooth motion video performance
- **Spatial Temporal Noise Reduction Filters:** Built-in filters practically eliminate image "noise" resulting in crystal-clear video.
- **Edge-Preserving De-Interlacing:** High performance video enhancement ensures that lines and edges are smooth regardless of their position on the screen.



©2004 Mitsubishi Digital Electronics America, Inc. Standard features, options and specifications subject to change without notice. Digital Light Processing, DLP, the DLP logo, and the DLP medallion are trademarks of Texas Instruments, Inc. All other trademarks or registered trademarks are the property of their respective holders. Cover photo courtesy of Draper, Inc.

* The projector lamp contains mercury. Please dispose of properly.